



Precision Sensors

Test Measurement OEM

MINIATURE HIGH PERFORMANCE PRESSURE SENSOR 4-20mA - ASUH SERIES - UP TO 6000 PSI

The ASUH Series of high performance sub-miniature pressure transducers have been designed for demanding installations where space is extremely limited and high vibration and temperature are anticipated.

This new design utilizes miniaturized hybrid components which allow savings in size and weight. The transducer has an enhanced performance at elevated temperature and is optimized for extreme installations such as on-engine or transmissions.

The modular construction and programmable amplifier provide a fast delivery time for standard and custom configurations. Pressure ranges are available between >500 to 6000 psi. For OEM applications we have many options available to customize these transducers.

Features

- Lightweight
- >500 psi to 6000 psi
- ±0.25% Accuracy
- 4-20mA
- -40 to +300°F

TECHNICAL SPECIFICATIONS

Pressure Reference	Absolute, Gauge and Sealed gauge
Standard Pressure Ranges (psi)	750, 1500, 3000, and 6000 <i>Any range >500 psi can be specified</i> <i>For ranges below 500 psi see ASUH Low Range datasheet</i>
Proof Pressure (overload)	200% of range
Burst Pressure	>500% of range
Accuracy	±0.25% FS Combined Linearity & Hysteresis (CNLH)
Thermal Effects	Zero ±0.01%FS/°F (Sensitivity ±0.01% of Reading /°1)
Output	4-20mA (±0.5%)
Power Supply	9-40Vdc
Operating Temperature Range	-40°F to 300°F (-40°C to +150°C)
Compensated Temperature Range	Standard temperature ranges-See Configurator on back page <i>Any range can be selected over the operating temperature.</i> <i>But for non-standard ranges please consult the factory.</i>
Bandwidth	1000Hz standard <i>Other frequencies available - please consult the factory.</i>
Construction	Stainless steel
Electrical Connection	20in 26AWG, 55spec wire + DR25 sleeve or Hermetic Connector - 8STA1-Y02-05PN170
Process Connection	3/8-24UNF (-3), 5/16-24UNF (-2), M6 x 1, M8 x 1 and M10 x 1
Protection Class	IP67 (Cable Option) Hermetic Seal (Connector Option)
EMC Protection	EN 50082-1
Vibration	Mil-Std-810C, curve L, 20G
Weight	0.95oz - Including cable 0.7oz - Connector option
Options	Cable length, connector fitted, thread size and labelling

PMC-STs, Inc. adopts a continuous development program which sometimes necessitates specification changes without notice.

Applications

- Engine Test
 - Automotive
 - Aviation
 - Dynamometers
- Satellite Launch Vehicles
 - Propellants
 - Chamber Pressure
 - Fuel Level
- Flight Test
 - Hydraulic Systems
 - Flight Control Systems
 - HVAC Systems
- Drone/UAV/AUV/ROV
 - Hydraulic Systems
 - Avionics
- Manufacturing
- Motorsport

sales@pmc1.com
Tel: 203-792-8686
Fax: 203-743-2051
www.pmc1.com
Represented by:

Part Number Configurator

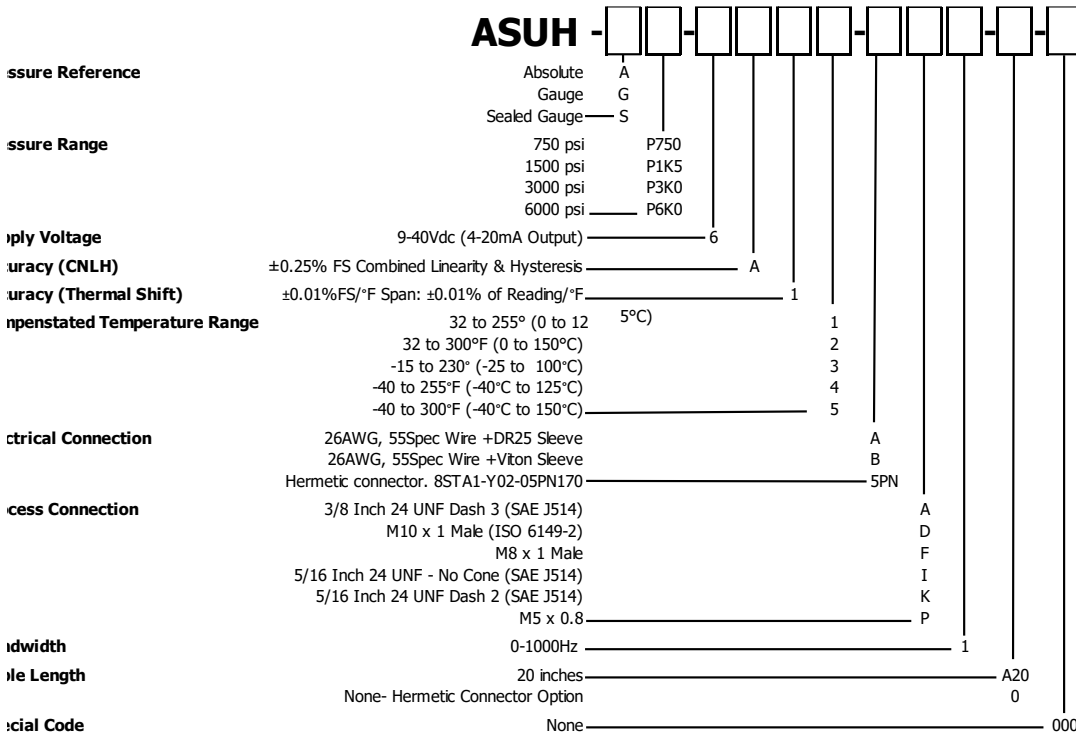

Precision Sensors Test Measurement OEM

Sensors For:

- Temperature
- Acceleration
- Pressure
- Position
- Torque
- Speed
- Angle
- Force

Services For:

- OEM
- On-Time Delivery
- Custom Engineering
- Application Engineering

Contact Us

PMC-STs, Inc.
11 Old Sugar Hollow Rd
Danbury, CT 06810 USA
Tel: 203-792-8686
Fax: 203-743-2051

sales@pmc1.com
www.pmc1.com

MECHANICAL DETAILS

Dimensions in inches

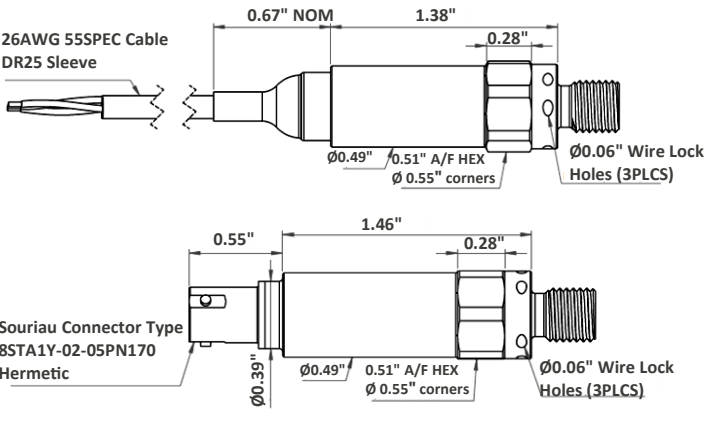

ELECTRICAL DETAILS

Cable Option		
+Ve Supply	0V Supply	Factory use only
Red	Black	White

Hermetic Connector Option			
+Ve Supply	GND	Factory use only	Not Connected
Pin 1	Pin 2	Pin 3	Pin 4 & 5